



# DS2 series servo drive

Manual

Wuxi Xinje Electric Co., Ltd.

Data No.: SC209 20110412 1.0



---

## ►► Safety notes

### ■ Confirmation

- ✓ Do not use the drivers that are broken, lack of parts or wrong types.

### ■ Installation

- ✓ Make sure all the external powers are cut off before install the drivers.

### ■ Wiring

- ✓ Please cut off all the powers before wiring.
- ✓ Connect the AC power to the power terminals of driver.
- ✓ Do not connect U, V, W terminals of driver with 3-phase power supply.
- ✓ Please use 2mm<sup>2</sup> cable to ground the GND terminal of driver.

### ■ Maintenance and running

- ✓ Install the panel cover when power on.
- ✓ Do not touch the terminals in 5 minutes after power off.
- ✓ Do not connect motor with load when test running.
- ✓ Set the suitable power consumption parameters before connecting the machine.
- ✓ Do not change the wiring with electricity.
- ✓ Do not touch the radiator when running.

## ►► Confirmation after getting the products

1. Please confirm the following items after getting the products.

Item	Contents
The type is what you ordered?	Check the label of driver and motor
Does the motor shaft rotate well?	Can rotate by manual. Cannot rotate by manual for brake types
Is there any damage?	Check if the cover has damage during transporting
Is the screw loose?	Check the screw with screwdriver
Check the motor code	Check if the driver and the motor code is

matched

Please contact us if there are any problems in these items.

## 2. Type

### (1) Servo driver

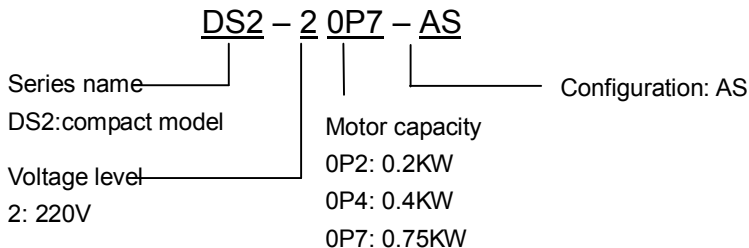

### (2) Servo motor

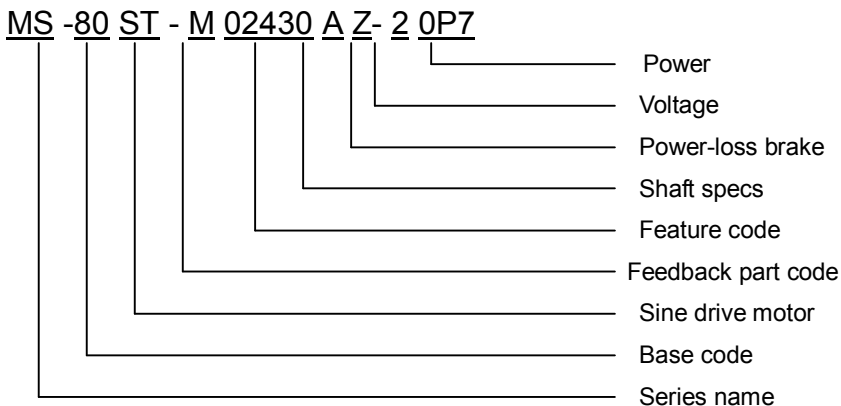

Base code: 60, 80, 90;

Feedback part code: M (optical pulse encoder)

Feature code: first 3 bits are rated torque; last 2 bits are rated speed;

For example: 00630: rated torque 0.637N·m, rated speed 3000rpm;

01330: rated torque 1.3N·m, rated speed 3000rpm;

---

Shaft spec: A- no bond; B- with bond;  
Power-loss brake: empty- no brake; Z- with brake;  
Voltage level: 2—220V;  
Power: 0P2: 0.2KW; 0P4: 0.4KW; 0P7: 0.75KW;

### 3. Parts introduction

#### (1) Servo motor

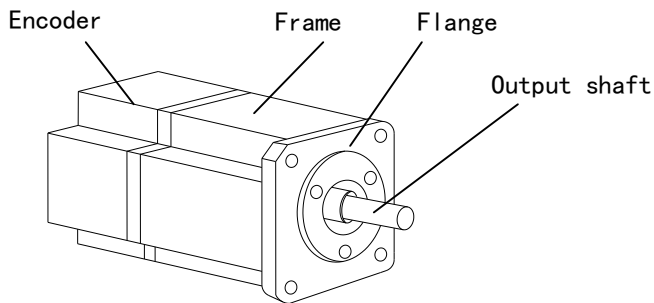

#### (2) Servo driver

- DS2-20P2-AS, DS2-20P4-AS, DS2-20P7-AS

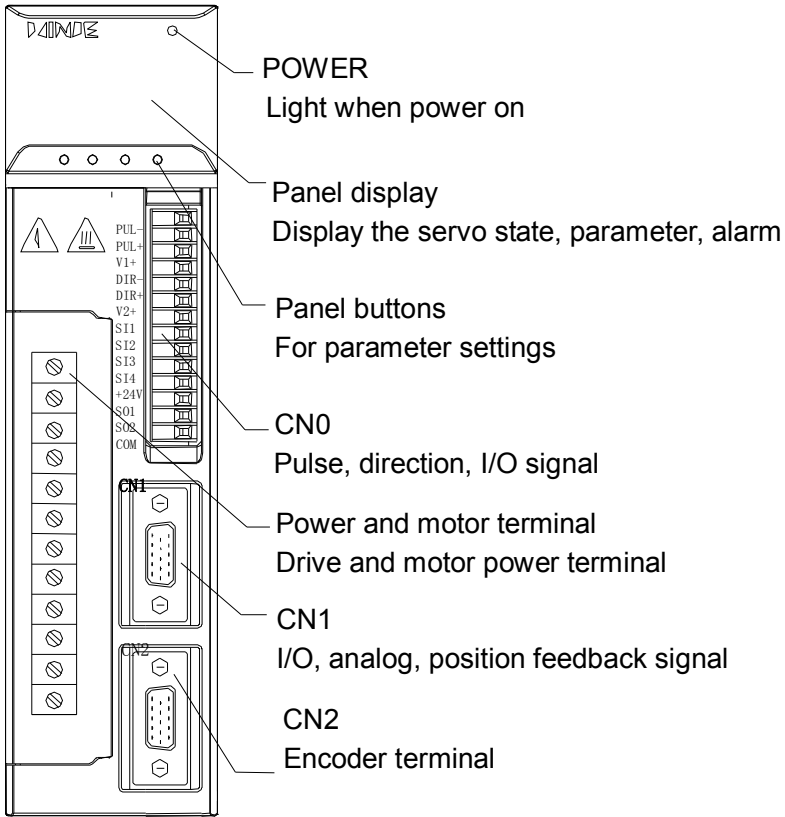

---

RS232 port  
Connect PC and HMI

DIP switch  
Turn on 2, 3, and 5  
for normal using

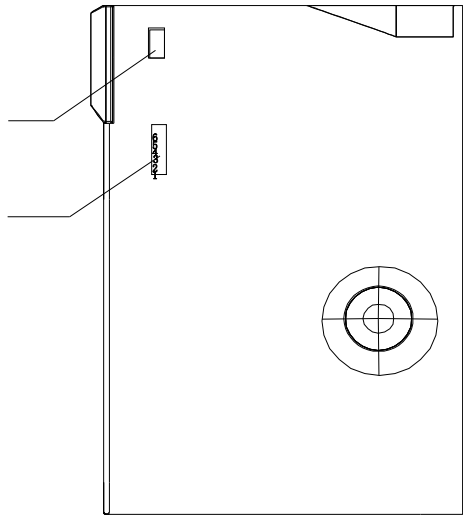

## ►► Installation

### 1. Servo motor

MS series servo motors can be installed either horizontally or vertically. The service life of the servo motor can be shortened or unexpected problems might occur if it is installed incorrectly or in an inappropriate location. Follow these installation instructions carefully.

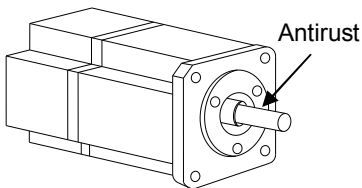

#### **Notes:**

The end of the motor shaft is coated with antirust. Before installing, carefully remove all of the paint using a cloth moistened with paint thinner. Avoid getting thinner on other parts of the servo motor.

---

(1) Storage temperature

Store the servomotor within  $-20\sim+60\text{ }^{\circ}\text{C}$  as long as it is stored with the power cable disconnected.

(2) Installation location

- Free of corrosive or explosive gases.
- Well-ventilated and free of dust and moisture.
- Ambient temperature of  $0^{\circ}$  to  $50^{\circ}\text{C}$ .
- Relative humidity (r.h.) of 20 to 80% with no condensation.
- Accessible for inspection and cleaning.

(3) Concentricity

Please use coupling when connecting to machine; keep the shaft center of servo motor and machine at the same line. It should be accord to the following diagram when installing the servo motor.

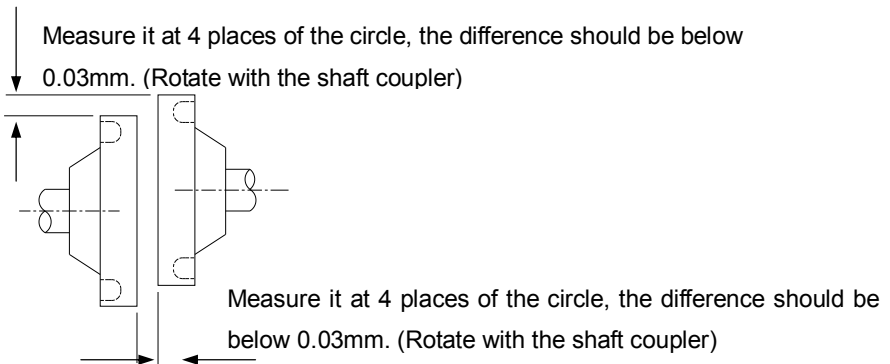

**Note:**

- If the concentricity is not enough, it will cause the vibration and bearing damage.
- When installing the coupler, prevent direct impact to the shaft. This can damage the encoder mounted on the shaft end at the opposite side of the load.

(4) Installation direction



---

MS series servo motors can be installed either horizontally or vertically.

(5) Avoid oil and water

Install a protective cover over the servomotor if it is used in a location that is subject to water or oil mist. Also use a servomotor with an oil seal when needed to seal the through-shaft section.

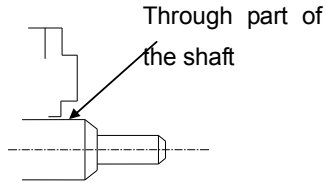

(6) Cable stress

Make sure that the power lines are free from bends and tension. Be especially careful to wire signal line cables so that they are not subject to stress because the core wires are very thin, measuring only 0.2 to 0.3mm<sup>2</sup>.

## 2. Servo drive

The DS2 series servo drivers are base-mounted servo drivers. Incorrect installation will cause problems. Follow the installation instructions below

(1) Storage temperature

Store the servo driver within -20~+85°C, as long as it is stored with the power cable disconnected.

(2) Installation location

The following precautions apply to the installation site.

Situation	Installation Precaution
Installation in a Control Panel	Design the control panel size, unit layout, and cooling method so the temperature around the servo drivers does not exceed

	50°C.
Installation Near a Heating Unit	Minimize heat radiated from the heating unit as well as any temperature rise caused by natural convection so the temperature around the servo drivers does not exceed 50°C.
Installation Near a Source of Vibration	Install a vibration isolator beneath the servo driver to avoid subjecting it to vibration.
Installation at a Site Exposed to Corrosive Gas	Corrosive gas does not have an immediate effect on the servo drivers, but will eventually cause electronic components and terminals to malfunction. Take appropriate action to avoid corrosive gas.
Other Situations	Do not install the servo driver in hot and humid locations or locations subject to excessive dust or iron powder in the air.

### (3) Installation direction

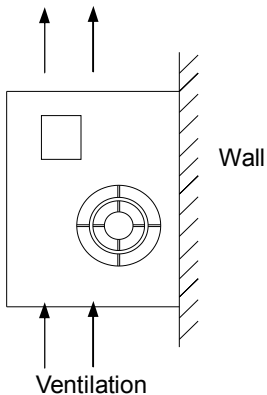

Install the servo driver perpendicular to the wall as shown in the figure. The servo driver must be oriented this way because it is designed to be cooled by natural convection or by a cooling fan.

#### (4) Installation

Follow the procedure below to install multiple servo drivers side by side in a control panel.

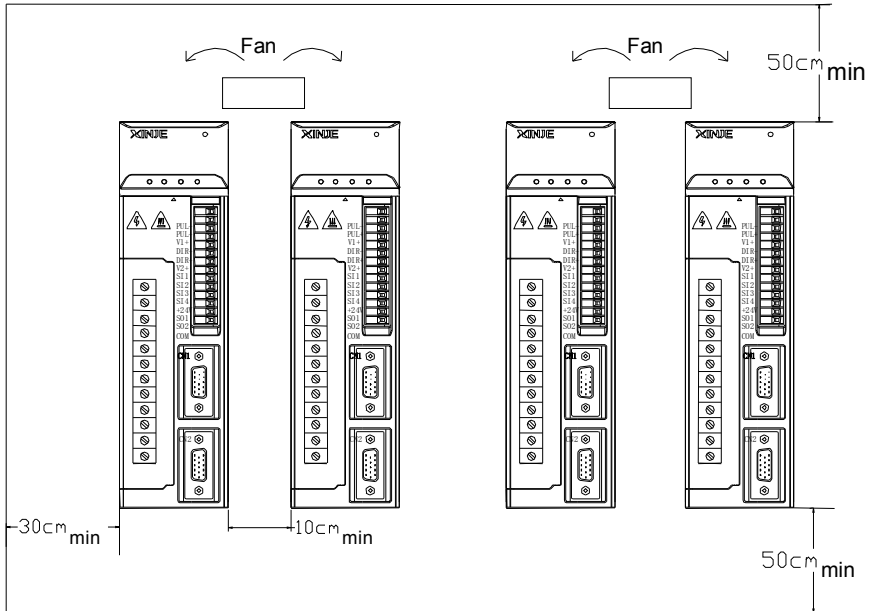

##### ■ Servo drive direction

Install the servo driver perpendicular to the wall and make the front panel towards operator.

##### ■ Cooling

Please leave enough space as the above diagram to ensure cooling by fans or natural ventilation.

##### ■ Side-by-side installation

As the above diagram, leave min 10cm space at horizontal direction, leave min 50mm space at vertical direction. Install cooling fans above the drive. Keep the uniform temperature inside the control panel to avoid overheat at local place.

- Ambient inside control panel
  - ❖ Ambient Temperature: 0~50 °C
  - ❖ Humidity: 90%RH or less
  - ❖ Vibration: 4.9m/s<sup>2</sup>
  - ❖ Condensation and Freezing: None
  - ❖ Ambient Temperature for Long-term Reliability: 50°C maximum

## ▶▶ Dimensions

### 1. Servo motor

#### ■ 60 series motor installation dimensions

Unit: mm

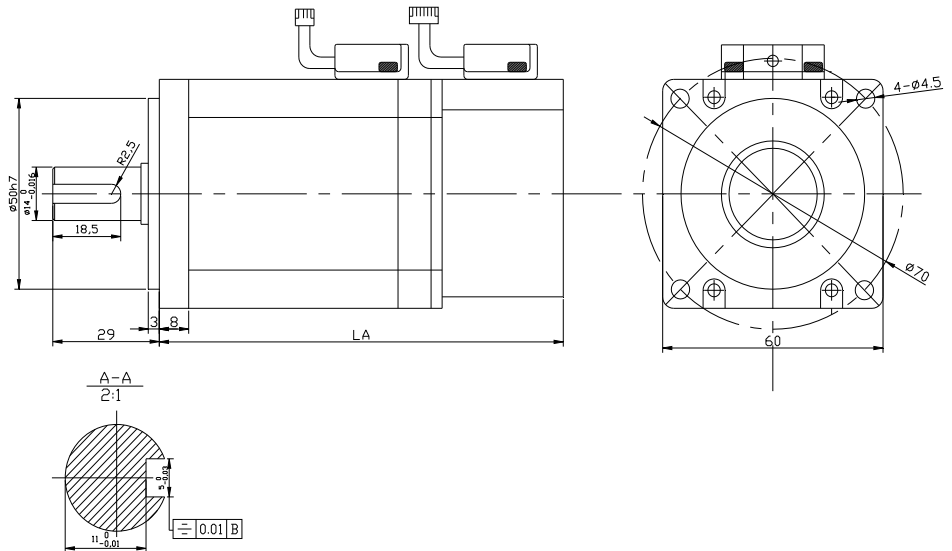

Type	LA
MS-60ST-M00630□□-20P2	110

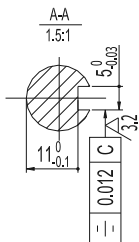
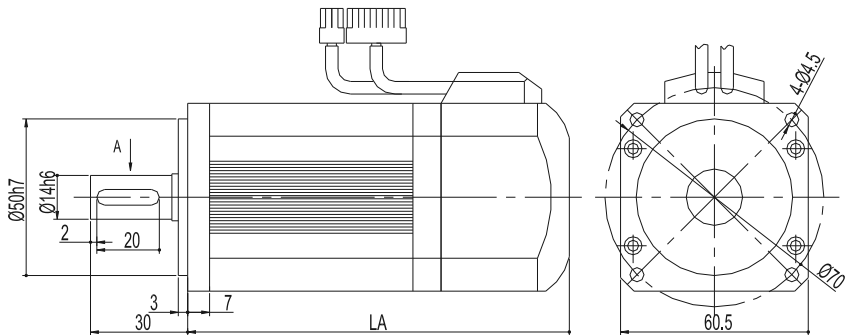

Type	LA	
	Normal	With brake
MS-60ST-M01330□□-20P4	146	189

■ 80 series motor installation dimensions

Unit: mm

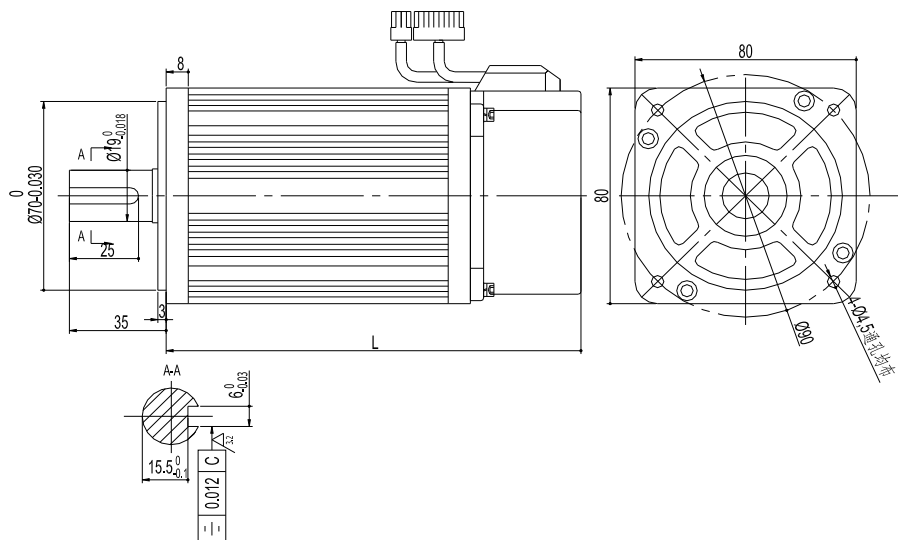

Type	LA	
	Normal	With brake
MS-80ST-M02430□□-20P7	150	191

■ MS-90ST-M02430□□-20P7 installation dimensions Unit: mm

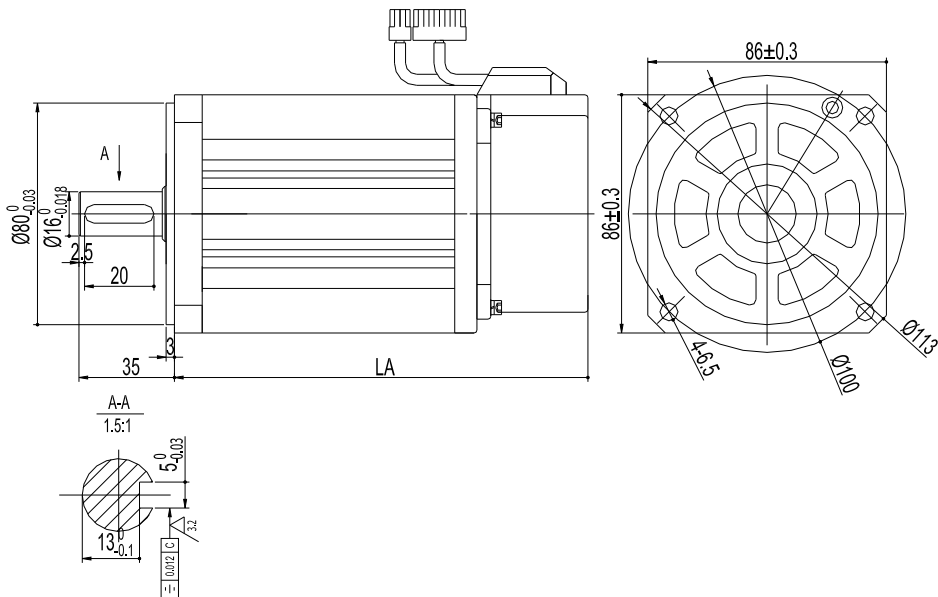

Type	LA	
	Normal	With brake
MS-90ST-M02430□□-20P7	149	194

2. Servo drive (unit: mm)

■ DS2-20P2-AS, DS2-20P4-AS, DS2-20P7-AS

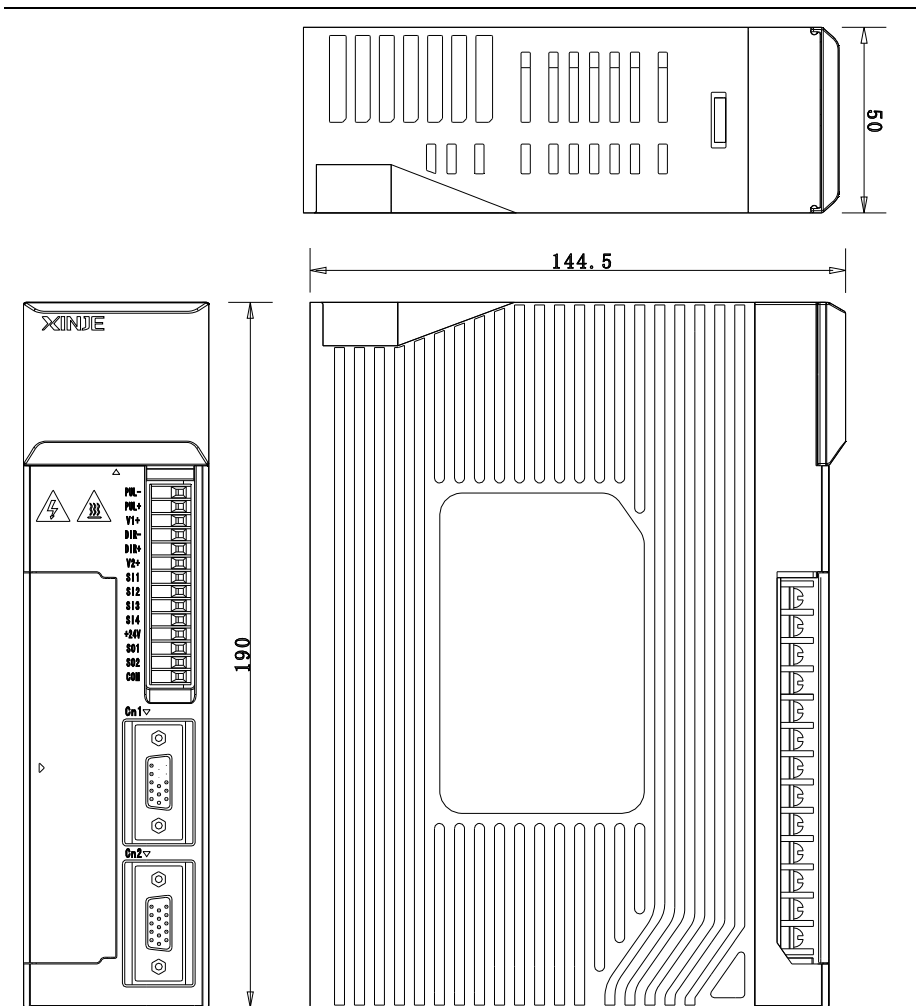

## ►► Wiring

### 1. Main circuit



## ■ DS2-20P2-AS, DS2-20P4-AS, DS2-20P7-AS

The terminal function of main circuit:

⊗	•
⊗	•
⊗	⊕
⊗	L1
⊗	L2
⊗	L3
⊗	P+
⊗	PB
⊗	U
⊗	V
⊗	W
⊗	⊕

Terminal	Function	Explanation
L1/L2/L3	Power input of main circuit	AC single-phase or 3-phase 200~240V, 50/60Hz
⊕	Ground terminal	Connect to ground terminal of motor
P+, PB	Regeneration brake resistor	Connect the regeneration resistor between P+ and PB
U, V, W	Motor terminal	Connect to motor
⊕	Ground terminal	Connect to motor ground terminal

### 2. Winding connector of servo motor

Signal	60、80、90 series motor
U	1
V	2
W	3
PE	4

### 3. I/O terminal (CN0, CN1)

The connector is looked at the soldering terminal:

DS2-20P2-AS

DS2-20P4-AS

DS2-20P7-AS

CN0

CN1(DB15)

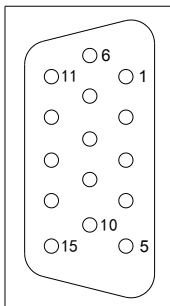
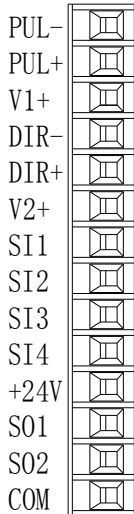

### ■ CN0, CN1 Terminal

DS2-20P2-AS

DS2-20P4-AS

DS2-20P7-AS

#### ■ CN0 terminals

No.	Name	Contents	No.	Name	Contents
1	PUL-	Pulse input PUL-	8	SI2	Input terminal 2
2	PUL+	Difference input	9	SI3	Input terminal 3

		PUL+			
3	V1+	Open collector +24V	10	SI4	Input terminal 4
4	DIR-	Direction input DIR-	11	+24V	Input terminal +24V
5	DIR+	Difference input DIR+	12	SO1	Output terminal 1
6	V2+	Open collector +24V	13	SO2	Output terminal 2
7	SI1	Input terminal 1	14	COM	Ground of output terminal

DS2-20P2-AS  
DS2-20P4-AS  
DS2-20P7-AS

■ CN1 (DB15) terminals

No.	Name	Contents	No.	Name	Contents
1	NC	Reservation	9	Z-	Encoder output Z-
2	NC	Reservation	10	B+	Encoder output B+
3	SI5	Input terminal 5	11	T-REF	Torque analog input
4	SO3	Output terminal 3	12	V-REF	Speed analog input
5	B-	Encoder	13	GND	GND for analog

		output B-			input
6	A+	Encoder output A+	14	A	RS485 +
7	A-	Encoder output A-	15	B	RS485 -
8	Z+	Encoder output Z+			

#### 4. I/O signals

##### (1) Input signal

Item	Input terminals	Function
Digital input	SI1~SI5	Multi-functional input terminals
Pulse input	PUL-, PUL+	P2-00=0: positive pulse P2-00=2: pulse
	DIR-, DIR+	P2-00=0: negative pulse P2-00=2: direction (sign)

##### (2) Output signal

Item	Output terminals	Function
Optical output	SO1~SO3	Multi-functional output terminals

#### 5. CN2 terminals

The connector is looked at the soldering terminal:

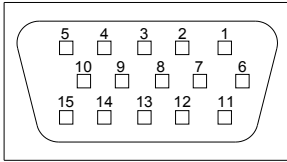

Drive terminal	Encoder terminal	Name	Drive terminal	Encoder terminal	Name
	60、80、90 Series motor			60、80、90 Series motor	
1	9	A+	2	4	B+
3	7	Z+	4	6	U+
5	11	W+	6	13	A-
7	14	B-	8	5	Z-
9	8	U-	10	15	W-
11	1	Shield	12	3	GND
13	2	5V	14	10	V+
15	12	V-			

## 6. Communication ports

- COM1

COM1 is RS232C port which can be used to connect PC for debugging. Do not set the panel display to bb or RUN when debugging.

The parameters of COM1 cannot be modified.

Baud rate 19200bps, 8 data bits, 1 stop bit, even parity, Modbus station no.1.

■ DS2-20P2-AS、DS2-20P4-AS、DS2-20P7-AS

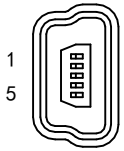

(5-pin port)

Terminal	Name	Explanation
1	TXD	RS232 send
2	RXD	RS232 receive
3	GND	RS232 ground

Note: please use the cable offered by Xinje company.

● COM2

The COM2 position of each type:

Type	Port	COM mode	Mark
DS2-20P2-AS DS2-20P4-AS DS2-20P7-AS	A (CN1-14) B (CN1-15)	RS485	This port cannot be used with COM1 at the same time.

The parameters of COM2 can be set through P0-04:

Parameter	Function	Default setting	Range
P0-04.0	Baud rate	6	0~9 0: 300 1: 600 2: 1200 3: 2400 4: 4800 5: 9600 6: 19200 7: 38400

			8: 57600 9: 115200
P0-04.1	Data bit	0	0: 8
P0-04.2	Stop bit	2	0: 2 bits; 2: 1 bit
P0-04.3	Parity bit	2	0~2 0: no parity 1: odd parity 2: even parity

Modbus station no. can be set through P0-03.

Parameter	Function	Unit	Default setting	Range
P0-03	Modbus station no.	—	1	1~255

Note: the above parameters will be worked after re-power on.

## 7. Typical wiring

- DS2-20P2-AS、DS2-20P4-AS、DS2-20P7-AS

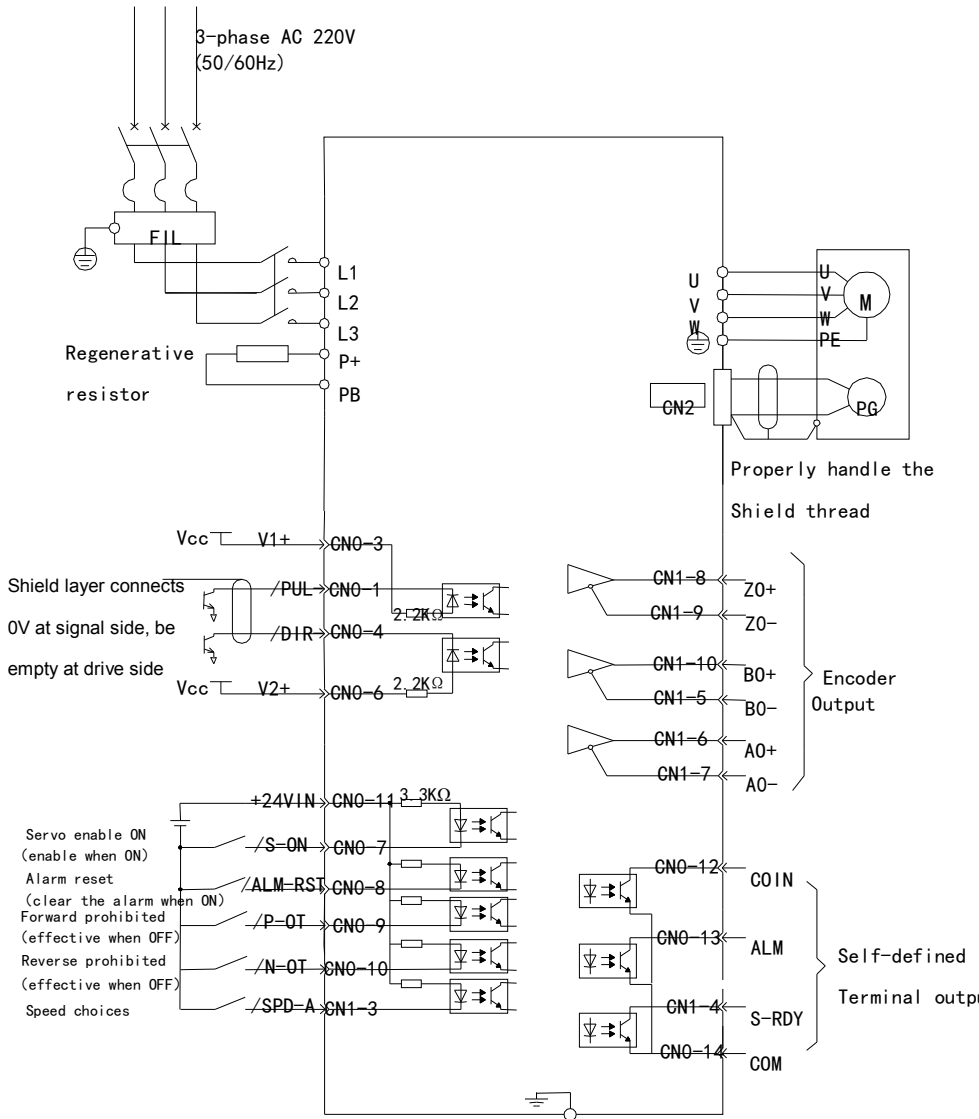



## ►► Use the control panel

### 1. Basic operation

The control panel can display the servo status, alarm code, command and set the parameters.

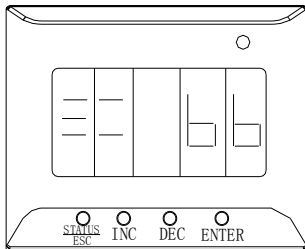

Buttons	Function
STATUS/ESC	Press: change the status, status return
INC	Press: increase the value Keep press: continuous increase the value
DEC	Press: decrease the value Keep press: continuous decrease the value
ENTER	Press: shift Keep press: enter data setting and checking

The control panel can display the running status, set the parameters and command. The basic status includes display status, parameter settings, monitor, auxiliary function, alarm status. Press STATUS/ESC to change the 5 status.

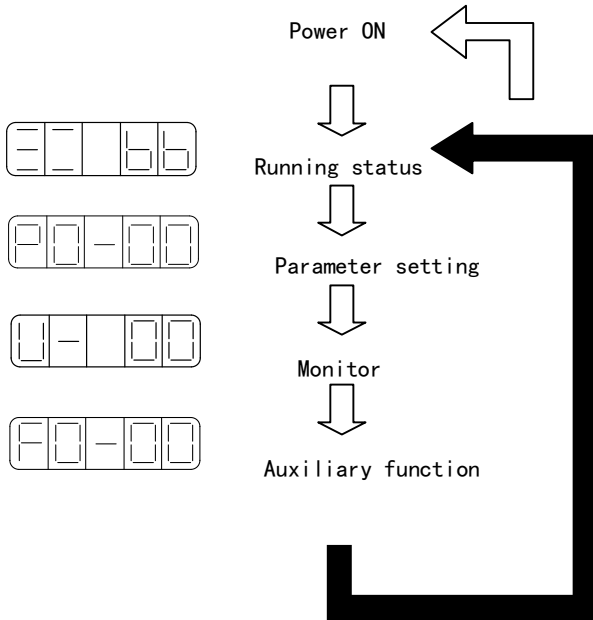

Display mode:

Monitor mode: U- XX: XX is monitor parameter code

Auxiliary function mode: FX-XX: the first X is group code; the second X is parameter code in this group.

Parameter settings mode PX-XX: the first X is group code; the second X is parameter code in this group.

Alarm mode E-XXX: XXX is alarm code.

## 2. Running status





The LED digits and code will show the status of servo drive.

- Use the status display

The servo enters status display when power on. If it cannot enter this status, press STATUS/ESC button.

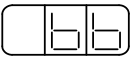
- The status contents

Code contents

Code	Contents
	Standby Servo is OFF (motor has no electricity)
	Run Servo enable (motor has electricity)
	Forward prohibit P-OT ON
	Reverse prohibit N-OT ON

### 3. Monitor status

The monitor status can show the command, I/O signal status, servo internal status.

The monitor status can be changed when motor is running.

- Use the monitor status

The following is the example of using U-16 monitor code.

- (1) Press STATUS/ESC to enter monitor status



- (2) Press INC, DEC or ENTER to choose the monitor code U-16, keep press ENTER to check the contents.



- (3) Now it will show the value in U-16.



(4) Press STATUS/ESC to return

The contents of monitor code:

Code	Contents	Unit
U-00	Motor real speed	Rpm
U-01	Input speed command	Rpm
U-02	Internal torque command	%
U-03	Rotate angle (physical angle)	0.1°
U-04	Rotate angle (electricity angle)	0.1°
U-05	Bus voltage	V
U-06	Module temperature	0.1℃
U-07	Input command pulse speed	Rpm
U-08	Shift command pulse	(0000~9999) *1
U-09		(0000~9999) *10000
U-10	Rotate angle (encoder value)	(0000~9999) *1
U-11		(0000~9999) *10000
U-12	Input command pulses	(0000~9999) *1
U-13		(0000~9999) *10000
U-14	Feedback command pulses	(0000~9999) *1
U-15		(0000~9999) *10000
U-16	Current position (cumulative value)	(0000~9999) *1
U-17		(0000~9999) *10000
U-18	Real-time current, 1 decimal place	0.1A

U-19	Analog input V-REF	0.01V
U-20	Analog input T-REF	0.01V
U-21	I/O signal status	
U-22	I/O terminal status	

U-21 can show the I/O signal status. The following is the I/O status.

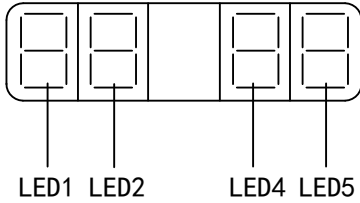

Fig 1

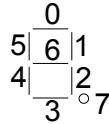

Fig 2

In fig 1, input status is shown in LED4 and LED5; output status is shown in LED1 and LED2. Fig 2 is the LED segment number.

Each segment meanings please refer to DS2 series servo manual.

U-22 can show I/O terminal status. The following is the I/O status.

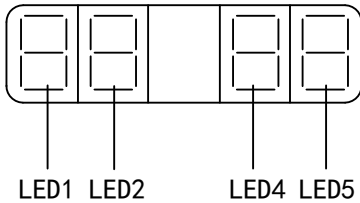

Fig 1

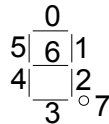

Fig 2

In fig1, input terminal status is shown in LED5; output terminal status is shown in LED2. Fig 2 is the LED segment number.

Each segment meanings please refer to DS2 series servo manual.

## 4. Auxiliary function

The control panel can performance some applications in auxiliary function.

Function code	Contents
F0-**	System information
F1-**	Auxiliary function, show auxiliary command and result
F2-**	Motor code
F3-**	Alarm information
F4-00	Reset to default settings
F5-00	External communication monitor

### ● Check the system information

Press STATUS/ESC to enter auxiliary function. Set the group no. to 0 in order to check system information. Press INC or DEC to change the code, keep press ENTER to check the information, press STATUS/ESC to return.

The contents of the system information:

Code	Contents	Code	Contents
F0-00	Motor code	F0-01	Series
F0-02	Type	F0-03	Production date: year
F0-04	Production date: month	F0-05	Production date: day
F0-06	Software version	F0-07	Hardware version

### ● Auxiliary function operation

In auxiliary function status, set the group to 1, press ENTER to go to code switching. Press INC or DEC to change the code, keep press ENTER to become effective. Press STATUS/ESC to return.

#### (1) Jog (F1-00)

**Make sure motor doesn't connect to the machine before jogging!**

Press ENTER to enable the motor. In enable status, press INC for forward jog, press

DEC for reverse jog. Press STATUS/ESC to exit.

4 statuses when jogging:

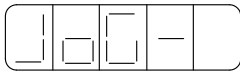
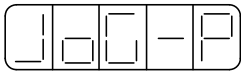
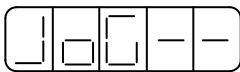
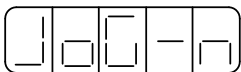
Status	Display	Status	Display
Idle		Forward	
Enable		Reverse	

(2) test run (F1-01)

**Make sure the motor doesn't connect to the machine before test running!**

**Please enter test run if servo connects to non-original encoder line and power line.**

Set F1-01 to 1, keep press ENTER to go to test run.

The display will show the following when test running.



If all the wires are connected correctly, the motor will run forward (direction is counterclockwise) in 5 seconds. The motor will shake if the wiring is not correct. Even worse, the drive will alarm. Please cut the power at this time and check the wiring.

Press STATUS/ESC to exit.

(3) current detection offset auto-tune

Please use current detection offset auto-tune when servo finishes updating or motor is not running smoothly after long time.

Choose F1-02 to enter current detection offset auto-tune, it will show rEF.

Press ENTER to run this function, it will show rEF and blink.

It will show done in 5 second when auto-tune is successful.

Press STATUS/ESC to exit.

(4) speed command offset auto-tune

Choose F1-03 to enter this function. It will show rEF\_o.

---

Press ENTER to perform the function, it will show rEF\_o.

It will show donE in 1 second when the auto-tune is successful.

Press STATUS/ESC to exit.

(5) torque command offset auto-tune

Choose F1-04 to enter this function. It will show rEF\_o.

Press ENTER to run this function, it will show rEF\_o and blink.

It will show donE in 1 second when the auto-tune is successful.

Press STATUS/ESC to exit.

(6) forced enable ( F1-05)

0: cancel enable

1: forced enable

- Change the motor code

In auxiliary function, set the group no. to 2 to change motor code.

Servo drive can match to different motors with similar power level. Please see the motor code on the product label.

The following are the steps of change the motor code.

(1) Press STATUS/ESC to enter auxiliary function.

(2) Press INC or DEC to set the group no. to 2, press ENTER to confirm.

(3) Keep press ENTER to show the current motor code.

(4) Press INC, DEC or ENTER until it show current motor code, keep press ENTER to input.

(5) Please re-power on the drive to make the changing effective.

- Check the alarm information

In auxiliary function, set the group to 3 to enter alarm status.

The following are the steps of show the alarm information.

(1) Press STATUS/ESC to enter auxiliary function.

(2) Press INC, DEC to set the group to 3, press ENTER to confirm.

(3) Press INC, DEC or ENTER to change the information code.



---

(4) Keep press ENTER to show the information.

Please refer to DS2 servo manual for detailed alarm information.

- Set to default value

The following are the steps of set to default value. The operations must be done when servo is OFF.

- (1) Press STATUS/ESC to enter auxiliary function.
- (2) Press INC or DEC, set the group no. to 4, press ENTER to confirm.
- (3) Keep press ENTER, it will show 0 and blink.
- (4) Set the value to 1, keep press ENTER to make it effective.
- (5) Re-power on the drive.

- External monitor

In auxiliary function, choose F5-00, it will show C-OUT. COM1 is available, control panel is invalid. User can debug the servo through PC.

Press STATUS/ESC to exit.

## 5. Parameter setting

The following steps show how to change the value of P3-09 from 2000 to 3000.

(1) Press STATUS/ESC, change to parameter setting status, press ENTER to confirm.

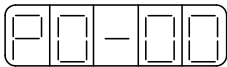

(2) The second LED will blink, press INC or DEC to change the value to 3, keep press ENTER to confirm.

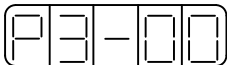

(3) The last two LEDs will blink at this time, press INC or DEC to change the value to 09, keep press ENTER to confirm.

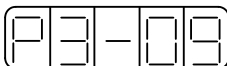

(4) It will show the value in P3-09. The lowest bit will blink; press ENTER to left shift the bit. Press INC, DEC or ENTER to change the value to 3000. Keep press ENTER to confirm.

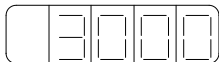

Repeat step2 to step4 to change the value.

(5) Press STATUS/ESC to exit.

## 6. Alarm

It will show alarm code when servo has error. The error code is E-XXX. Press ENTER to reset the error.

If the servo power is off caused by servo error, the alarm doesn't have to clear.

Note: please find out the alarm reason before clear the alarm.

## ▶▶ Parameter list

Effective time: “○” modify when servo OFF, effective when servo ON; “●” modify anytime, effective when re-power on; “√” modify anytime, effective immediately

Parameter:  $PX-XX=\overset{xx}{\times}$   $\overset{xx}{\times}$   
 $PX-XX.H \leftarrow \downarrow \quad \downarrow \rightarrow PX-XX.L$

### 1. Function selection P0(address: 0000~00FF)

P0	Function	Unit	Default value	Range	Effective
-					
00	Main mode	-	0	0	
01	Sub-mode 1 0: idle 1: torque (command) 2: torque (analog)	-	6	0~7	○

	3: speed (terminal command) 4: speed (analog) 5: position (internal) 6: position (pulse) 7: speed (pulse)				
02	Sub-mode 2 0~7 ditto	-	0	0~7	○
03	Modbus station no. of COM2	-	1	1~255	●
04	Parameters of COM2	-	n.2206	n.0000 ~ n.2209	●
05	Rotation direction 0: look at load side, counterclockwise is forward. 1: look at load side, clockwise is forward.	-	0	0、1	●
06	06.L: stop mode when servo OFF or alarm. DS2 is inertia stop. Keep inertia state after stop.	-	2	0~2	●
	06.H: stop mode when over range 0~1: inertia stop. Keep inertia state after stop. 2: deceleration stop. Change to zero clamp state after stop. Torque value: P4-06 urgent stop torque 3: deceleration stop. Change to inertia motion after stop. Torque value: P4-06 urgent stop torque.	-	2	0~3	●

07	T-REF distribution 0: undefined. 1: T-REF is external torque limit input. 2: undefined. 3: P-CL, N-CL is ON, T-REF is external torque limit input.	-	0	0~3	○
08	V-REF distribution 0: undefined. 1: V-REF external speed limit input.	-	0	0、1	○

## 2. Control parameter P1(address: 0100~01FF)

P1-	Name	Unit	Default value	Range	Effective time
00	Speed loop gain	1Hz	100	1~5000	√
01	Speed loop integral time	0.1ms	400	1~50000	√
02	Position loop gain	1/s	100	1~2000	√
03	Reserved				
04	Second speed loop gain	1Hz	250	1~5000	√
05	Second speed loop integral time	0.1ms	10000	1~50000	√
06	Second position loop gain	1/s	250	1~2000	√
07	Reserved				
08	Reserved				
09	Position loop feed forward gain	1%	0	0~100	√
10	Feed forward filter time	0.01ms	0	0~65535	√

### 3. Position control parameter P2 (address: 0200~02FF)

P2	Function	Unit	Default value	Range	Effective time
-					
00	Command pulse mode 1: AB phase pulse (90° phase, 4-time) 2: sign and pulses	-	2	1、2	●
01	Position command filter 0: first order filter 1: smooth filter	-	0	0、1	●
02	Electronic gear ratio (numerator)	-	1	1~65535	√
03	Electronic gear ratio (denominator)	-	1	1~65535	√
04	Position command filter time	1ms	0	0~100	●
05	Reserved				
06	Command pulse frequency at rated speed	100Hz	5000	1~10000	○
07	Speed command pulse filter time	0.1ms	20	0~1000	√
08	Reserved				
09	Reserved				
10	Internal position mode	-	n.0000		●
11	First segment of pulse (low bit)	1	0	-9999~ +9999	○
12	First segment of pulse (high bit)	1	0	-9999~ +9999	○
13	First segment speed	0.1rpm	0	0~50000	○
14	First segment adjusting time	1ms	0	0~65535	○

15	First segment command filter time	0.1ms	0	0~65535	○
P2-16~P2-90 are 2~16 segment parameters, P2-91~P2-93 are reserved.					
94	The times pass Z phase signal after leaving the limit switch	times	2	1~65535	○
95	The speed close to the proximity switch	0.1rpm	600	0~50000	○
96	The speed leave the proximity switch	0.1rpm	100	0~50000	○

#### 4. Speed control P3 (address: 0300~03FF)

P3 -	Name	Unit	Default value	Range	Effective time
00	Analog value of rated speed	0.01V	1000	150~3000	○
01	Internal speed 1	rpm	100	-5000~+5000	√
02	Internal speed 2	rpm	200	-5000~+5000	√
03	Internal speed 3	rpm	300	-5000~+5000	√
04	JOG speed	rpm	100	0~1000	√
05	Acceleration time of soft start	1ms	0	0~65535	○
06	Deceleration time of soft start	1ms	0	0~65535	○
07	Speed command filter time	0.01ms	0	0~65535	○
08	Speed feedback filter time	0.01ms	20	0~65535	○
09	Max speed limit (MAX)	rpm	Different	0~5000	●

	speed)		for each motor		
10	Speed command input dead area voltage	0.01V	0	0~100	○

### 5. Torque control P4 (address: 0400~04FF)

P4-	Name	Unit	Default value	Range	Effective time
00	Analog value of rated torque	0.01V	1000	150~3000	○
01	Torque command filter time	0.01ms	0	0~65535	○
02	Forward torque limit	1%	300	0~300	√
03	Reverse torque limit	1%	300	0~300	√
04	Forward external torque limit	1%	100	0~300	√
05	Reverse external torque limit	1%	100	0~300	√
06	Urgent stop torque	1%	300	0~300	○
07	Internal speed limit in torque control mode	rpm	2000	1~5000	√
08	Reserved				
09	Internal torque command setting	1%	0	-300~300	√
10	Torque command input dead area voltage	0.01V	0	0~100	○

### 6. Signal parameter P5 (address: 0500~05FF)

P5	Name	Unit	Default value	Range	Effective time
-					
00	Positioning end width /COIN	Command	7	0~250	○

		pulse			
01	Zero clamp speed /ZCLAMP	rpm	10	0~300	○
02	Rotation checking speed /TGON	rpm	20	1~1000	○
03	Co-speed checking signal width /V-CMP	rpm	10	1~250	○
04	Near output signal width /NEAR	Command pulse	50	0~10000	○
05	Deviation pulse limit	256 command pulses	1000	0~65535	○
06	Servo OFF delay time (brake command)	1ms	0	0~500	○
07	brake command output speed	rpm	100	0~5000	○
08	Brake command wait time	1ms	500	10~1000	○
09	Input filter time	5ms	0	0~100	√
10	/S-ON servo signal 0000: signal invalid 0001: input positive signal to terminal SI1 0002: input positive signal to terminal SI2 0003: input positive signal to terminal SI3 0004: input positive signal to terminal SI4 0005: input positive signal to terminal SI5	—	※1	※3	●



	0006: input positive signal to terminal SI6 0010: signals are valid 0011: input negative signal to terminal SI1 0012: input negative signal to terminal SI2 0013: input negative signal to terminal SI3 0014: input negative signal to terminal SI4 0015: input negative signal to terminal SI5 0016: input negative signal to terminal SI6				
11	/P-CON proportion command, ditto	—	※1	※3	●
12	/P-OT forward prohibition, ditto	—	※1	※3	●
13	/N-OT reverse prohibition, ditto	—	※1	※3	●
14	/ALM-RST clear the alarm, ditto	—	※1	※3	●
15	/P-CL forward external torque limit, ditto	—	※1	※3	●
16	/N-CL reverse external torque limit, ditto	—	※1	※3	●
17	/SPD-D internal speed choice, ditto	—	※1	※3	●
18	/SPD-A internal speed choice, ditto	—	※1	※3	●

19	/SPD-B internal speed choice, ditto	—	※1	※3	●
20	/C-SEL control mode choice, ditto	—	※1	※3	●
21	/ZCLAMP zero clamp, ditto	—	※1	※3	●
22	/INHIBIT pulse command prohibition, ditto		※1	※3	●
23	/G-SEL gain switching, ditto	—	※1	※3	●
24	/CLR clear pulse offset, ditto	—	※1	※3	●
25	/CHGSTP change step signal, ditto	—	※1	※3	●
26	Reserved				
27	Reserved				
28	/COIN positioning end 0000: not output to the terminal 0001 : output positive signal from terminal SO1 0002 : output positive signal from terminal SO2 0003 : output positive signal from terminal SO3 0011 : output positive signal from terminal SO4 0012 : output positive signal from terminal SO5 0013 : output positive signal from terminal SO6	—	※2	※4	●
29	/V-CMP co-speed checking,	—	※2	※4	●

	ditto				
30	/TGON rotation checking, ditto	—	※2	※4	●
31	/S-RDY ready, ditto	—	※2	※4	●
32	/CLT torque limit, ditto	—	※2	※4	●
33	/MLT speed limit checking, ditto	—	※2	※4	●
34	/BK brake interlock, ditto	—	※2	※4	●
35	/WARN warn, ditto	—	※2	※4	●
36	/NEAR near, ditto	—	※2	※4	●
37	/ALM alarm, ditto	—	※2	※4	●
38	/Z Z signal of encoder, ditto	—	※2	※4	●

※1: the default value of input terminals, please refer to table 2.

※2: the default value of output terminals, please refer to table 4.

※3: the input terminal distributions please refer to table 1.

※4: the output terminal distributions please refer to table 3.

Table 1: Input signal distributions

Input terminal parameters	Servo drive	Range
P5-10~P5-24	DS2-20P2-AS DS2-20P4-AS DS2-20P7-AS	n.0000~n.0005 n.0010~n.0015
The range is different as the input terminals of servo drive.		

Table 2: default settings of input terminals

SI1	SI2	SI3	SI4	SI5
-----	-----	-----	-----	-----

DS2-20P2-AS DS2-20P4-AS DS2-20P7-AS	/S-ON	/ALM-RST	/P-OT	/N-OT	/SPD-A
---	-------	----------	-------	-------	--------

Table 3: output signal distributions

Output terminal parameters	Servo drive	Range
P5-28~P5-38	DS2-20P2-AS DS2-20P4-AS DS2-20P7-AS	n.0000~n.0003 n.0010~n.0013
The range is different as the output terminals of servo drive.		

Table 4: the default settings of output terminals

	SO1	SO2	SO3
DS2-20P2-AS DS2-20P4-AS DS2-20P7-AS	/COIN	/ALM	/S-RDY

## ▶▶ Alarm information

Code	Explanations	Reasons	Solution
E-001	Program damage	Cannot pass the program self-test	Re-download the program, contact us
E-002	Parameter	Cannot pass the	Re-power on the drive or

	damage	parameter self-test	contact us
E-003	bus overvoltage	Grid voltage is too high or not connect to regenerative resistor, regenerative resistor is broken or value to large	Check the grid and regenerative
E-004	Bus under voltage	Grid voltage is too low	Check the grid
E-005	Regenerative resistor error	Regenerative resistor is not functional	Check the regenerative resistor
E-006	Module temperature too high	Running for long time with large load will cause module temperature too high	Use small load, enhance the ventilation, check if the fan is working when servo is enable; decrease the environment temperature
E-007	Over current	UVW output short circuit or motor error	Change the motor, check the Uvw wiring
E-008	Over speed	Motor speed is too fast, motor Uvw connection is error	Check if there is external force make the motor over speed, check motor Uvw connection
E-009	Analog input error	Input voltage is error when two channels analog is zeroing	Input correct voltage when analog zeroing
E-010	Position offset is too large	The difference between setting value and actual value is larger than limits in position control mode	Check if the motor is blocked, decrease the position setting speed, increase the deviation pulse limits P5-05
E-011	Motor Uvw is short circuit	External short circuit at first power-on self-test	Check motor Uvw connection, change the

			broken motor
E-012	Motor UVW current error	Current collection circuit is error	Check motor wiring, change servo drive
E-013	Encoder UVW open circuit	Not connect encoder, encoder wiring is error or damaged	Check encoder wiring, re-connect it after power off, change the encoder
E-014	Encoder ABZ open circuit	Not connect encoder, encoder wiring is error or damaged	Check encoder wiring, re-connect it after power off, change the encoder
E-015	Speed changing is too fast (encoder feedback error)	Encoder wiring error, encoder has external interference	Check encoder wiring, add shield layer for encoder wire
E-016	Over load	Run over load for long time	Decrease the time of overload running, change a motor with larger rated power
E-017	Power failure when running	Grid power is off when running	Re-power on after the grid voltage is stable
E-018	Erase parameter error	Cannot erase parameter , the voltage is too low when power on initialization	Check the power supply and re-power on
E-031	Motor code error	The motor code doesn't match the drive	Set F2-00 motor code
E-032	System initialization is failure	System IC chip is broken	Contact us

---

## ▶▶ General debug steps

- (a) Make sure there is no obvious damage on the product before power on.
- (b) Connect servo drive and motor. Please note the power terminal UVW and the servo drive terminal UVW must one-to-one connect. Otherwise, the servo motor will be blocked or run too fast.
- (c) Power on, the servo drive panel will display bb.
- (d) Enter F2-00, set the value same to the motor code on the motor label, then re-power on. Please note the compatible motor is different for each servo drive.
- (e) Re-power on the drive, enter F1-02 to do current offset auto-adjustment, please refer to auxiliary function for details.
- (f) Set F1-01 to 1, check the motor running state. If the motor runs smoothly, the connection is correct. Otherwise, please check the wiring.
- (g) If the connection is correct, enter F1-00 for jog running. Make sure there is no error, and then connect the motor to the machine.
- (h) Set the servo drive parameters as actual needs, and adjust it depend on actual conditions.





## ▶▶ Motor code

Motor type	Power KW	Torque Nm	Speed RPM	Current A	Overload times	Motor code
MS-60ST-M006 30-20P2	0.2	0.637	3000	1.8	3	1003
MS-60ST-M013 30-20P4	0.4	1.27	3000	2.5	3	0004
MS-80ST-M024 30-20P7	0.75	2.39	3000	3.0	3	0011
MS-90ST-M024 30-20P7	0.75	2.4	3000	3.0	3	0021

## ▶▶ Motor code

Servo drive	Motor code
DS2-20P2-AS	1003
DS2-20P4-AS	0004
DS2-20P7 -AS	<b>0011 (default), 0021</b>

# XINJE

**Xinje Electronic Co., Ltd.**

4th Floor Building 7,Originality Industry park,

Liyuan Development Zone, Wuxi City, Jiangsu

Province 214072

Tel: 86-510-85134136

Fax: 86-510-85111290